

BIG BETTY™ ASSEMBLY INSTRUCTIONS



Product. No. 1014

Skill Level One



Things You'll Need To Assemble this Kit:
Hobby Knife, Pencil, Brush



Sandpaper (220 or 320 Grit)
Sanding Sealer

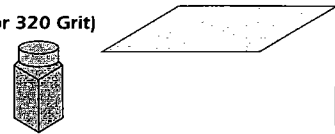

White Glue

Aliphatic Resin glues work best such as TITEBOND or ELMER'S CARPENTER'S WOOD GLUE - ELMER'S WHITE SCHOOL GLUE also works but dries slower.



Tape

Scotch Magic Tape or Paper Masking Tape



BEFORE STARTING ASSEMBLY READ THROUGH THESE INSTRUCTIONS. IT IS BEST TO TEST FIT ALL PARTS BEFORE APPLYING ANY GLUE. READ AND FOLLOW THE NAR MODEL ROCKET SAFETY CODE.

PARTS LIST

- A. 49001 Motor Clip
- B. 14000 Blue Thrust Ring
- C. 10303 Yellow Motor Mount Tube
- D. 16007 Flat Centering Rings (2)
- E. 33022 Die - cut Balsa Fin Set
- F. 11509 18 Inch White Body Tube
- G. 20400 Plastic Nose Cone
- H. 10001 2 inch Launch Lug
- I. 50012 24 inch White Elastic Shock Cord
- J. 50053 24 inch Yellow Kevlar Shock Cord
- K. 29106 14 inch Parachute
- L. R306-2 Gripper Tabs
- M. 50100 Pack of 36 Inch Shroud Lines
- N. 90076 Instruction Sheet
- O. 90176 Launch Procedures Sheet
- P. 91522 Decal

* Kevlar is a registered trademark of Dupont

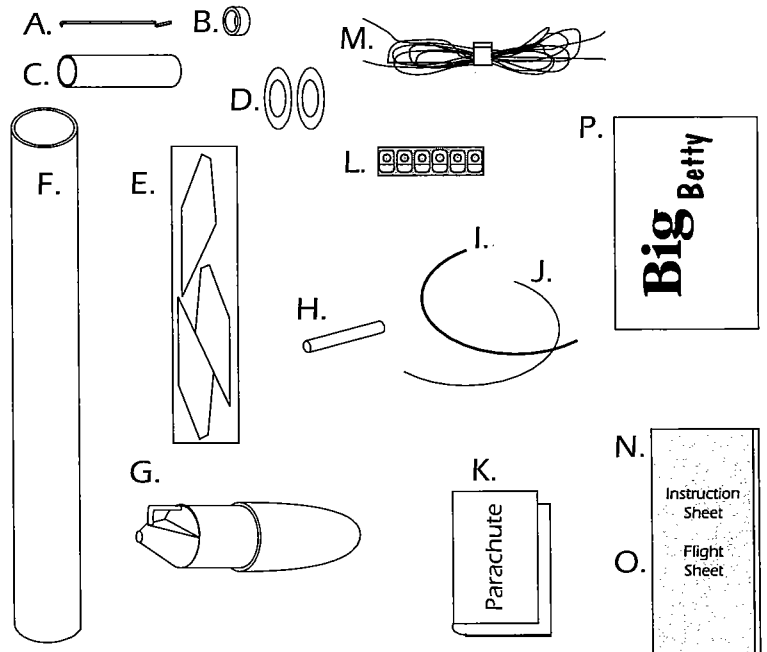

PARTS NOT TO SCALE

STEP 1

- A. Hold the Yellow Kevlar Shock Cord and the White Elastic Shock Cord side by side. Pull one end of each cord so that they are even with each other. While holding the two cords together, tie a single parallel overhand knot approximately one inch in from the even ends as shown.
- B. Gently pull on both cords to set the knot and prevent it from slipping.
- C. Apply a small amount of white glue on the ends of both cords to prevent them from fraying.

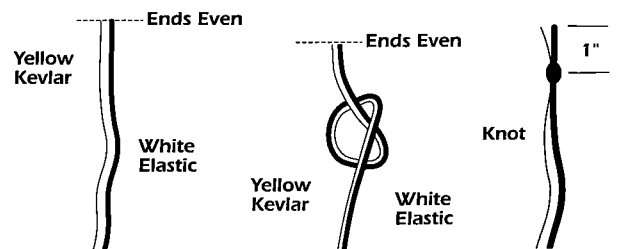

NOTE: THIS IS A VERY IMPORTANT STEP. IF YOU TIE A DIFFERENT TYPE OF KNOT THE SHOCK CORDS MAY SEPARATE DURING FLIGHT.

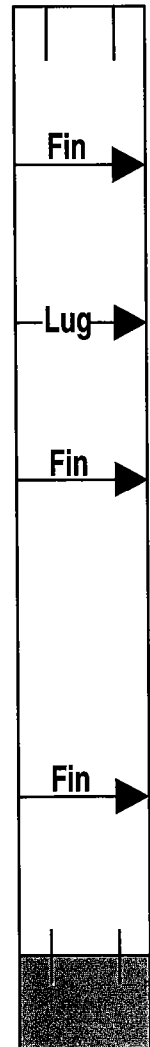
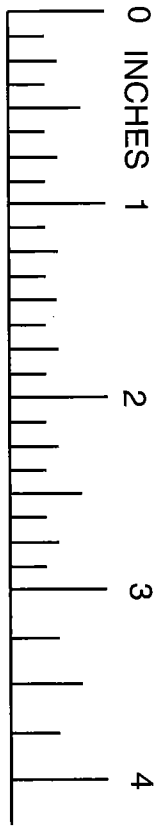

STEP 2

- Use a sharp hobby knife to cut a shallow "V" slot in the Blue Thrust Ring as shown. Test fit the Blue Thrust Ring into one end of the Yellow Motor Mount Tube. If the fit is tight, sand the outside of the Blue Thrust Ring until you get a looser fit.
- Tie the Yellow Kevlar Shock Cord onto the Blue Thrust Ring using two overhand knots as shown. Be sure the shock cord lays in the "V" you made in the Blue Thrust Ring.

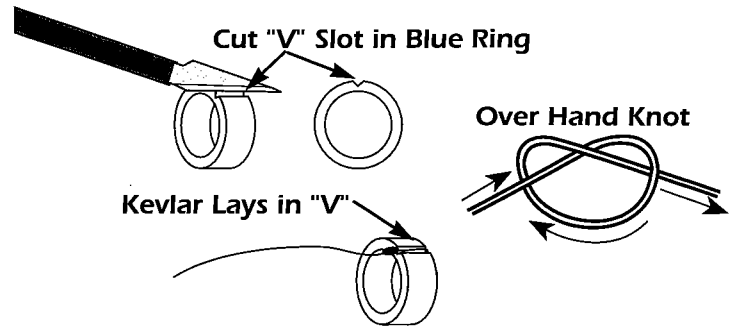

STEP 3

- Apply white glue around the inside edge of the Yellow Motor Mount Tube as shown.
- Insert the Blue Thrust Ring into the Yellow Motor Mount Tube with the Yellow Kevlar and knot facing as shown until it is even with the end of the Yellow Motor Mount Tube.

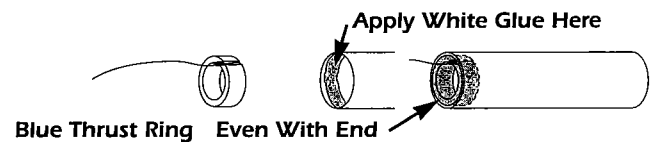

STEP 4

- Make a slight bend in the motor clip as shown. Insert the clip into the Yellow Motor Mount Tube.
- Wrap a piece of tape all the way around the Yellow Motor Mount Tube to hold the motor clip in place.

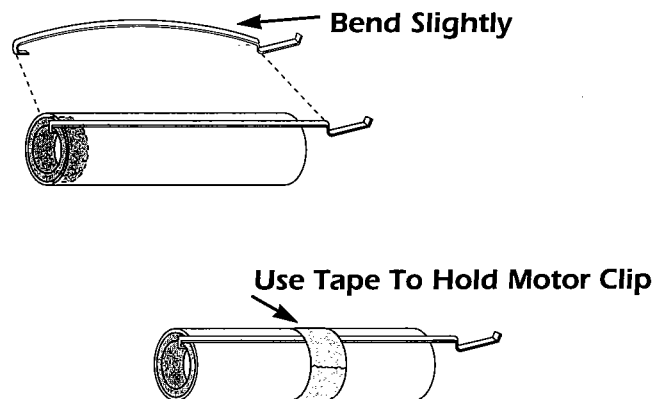

STEP 5

- Apply a bead of white glue around the Yellow Motor Mount Tube 1/2 inch from rear end as shown.
- Slide one of the paper centering rings onto the Yellow Motor Mount Tube and into the bead of glue. Check to be sure ring is aligned straight on Yellow tube as shown.
- Apply a bead of white glue around the Yellow Motor Mount Tube 1/2 inch from the forward end as shown.
- Slide the remaining paper centering ring onto the Yellow Motor Mount Tube and into the bead of glue. Check to be sure ring is aligned straight on Yellow tube as shown.

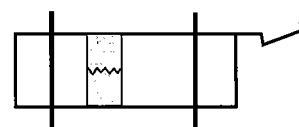
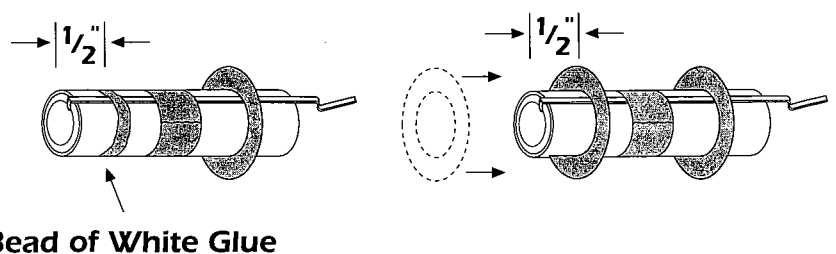
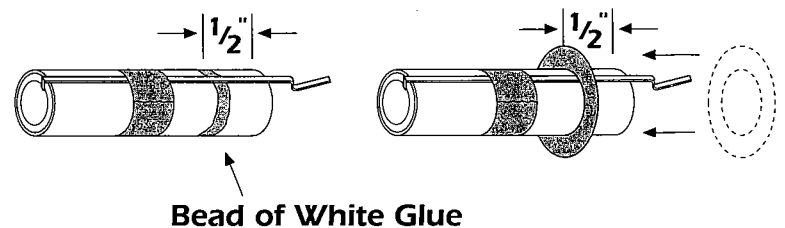

STEP 6

- "Feed" the shock cord attached to the motor mount assembly into the White body tube until the cord comes out the other end of the white tube.
- Apply white glue around the inside of the White body tube as shown.
- Immediately insert the motor mount assembly into the White body tube and PUSH INTO THE BODY TUBE WITH ONE FAST & SMOOTH MOTION until the Yellow motor mount tube extends out from the end of the white body tube 1/4 inch as shown.
- Apply additional white glue to the exposed centering ring/body tube joint as shown. Wipe away excess glue with your finger.

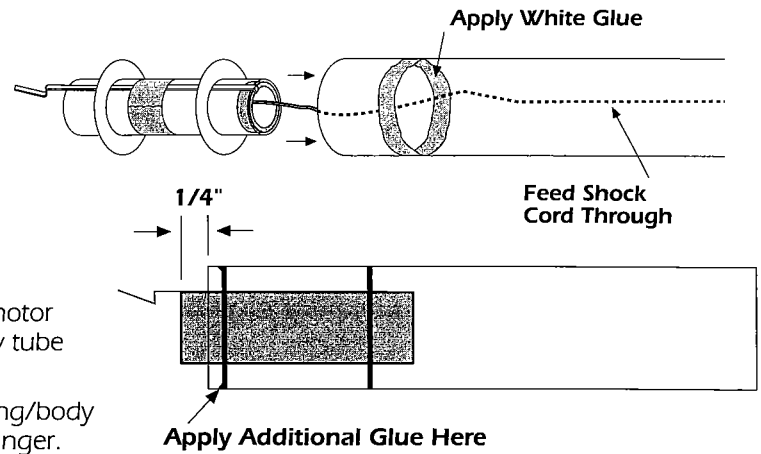

STEP 7

- Cut out the tube marking guide from the front page of the instruction sheet
- Wrap the tube marking around the body tube. Align the arrow that is marked "Launch Lug" with the motor clip. Mark the body tube at each of the arrows with a pencil.
- Use a door frame as a guide and extend each of the fin pencil marks 6 inches up from the rear of the body tube. Extend the Lug Line 10 inches from the rear.

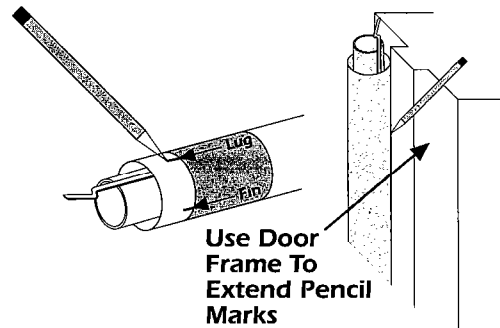

STEP 8

- Carefully remove each of the three die-cut balsa fins from the sheet with a sharp hobby knife.
- Stack the fins together and sand all edges smooth.
- Rub a small line of white glue into the root edge of each fin and set aside to dry.

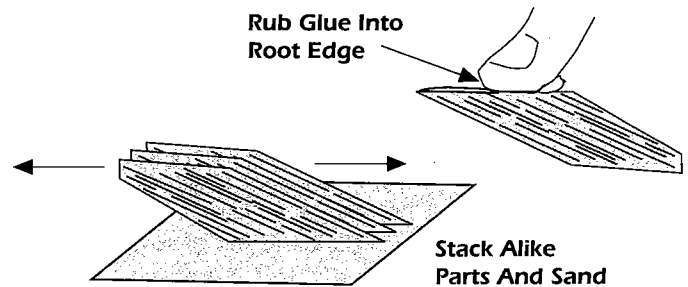

STEP 9

- Apply a small line of white glue along the root edge of a fin and position it along one of the fin lines even with end of the body tube. Adjust the fin so that it projects straight away from the body tube as shown. Allow the glue to set for a few minutes before attempting to glue on the remaining fins. Repeat this step for the remaining two fins.
- After the glue is completely dry apply a small bead of white glue to both sides of a fin-body tube joint. Smooth out the glue with your finger. Wipe excess glue off your finger onto a tissue or paper towel.
- Repeat the above step for the remaining fin-body tube joints.

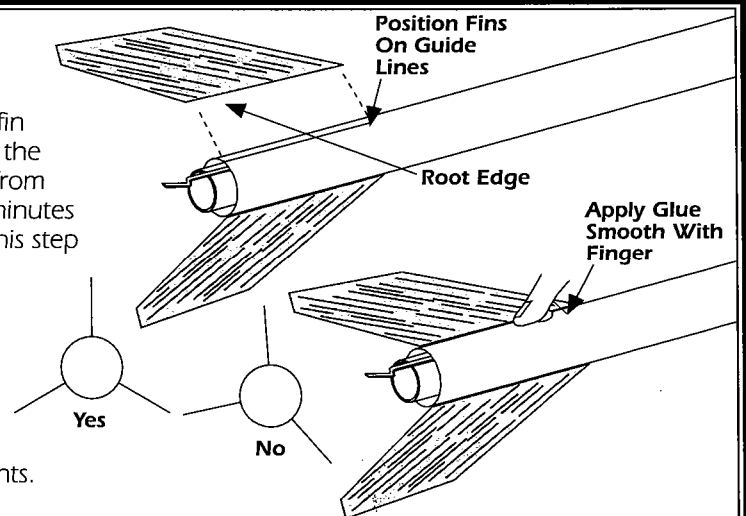

STEP 10

- Make a pencil mark on the launch lug line 8 inches from the rear of the rocket as shown.
- Apply white glue to the root edge of the launch lug and place it along the pencil line with one end even with the mark 8 inches from the rear of the rocket as shown.

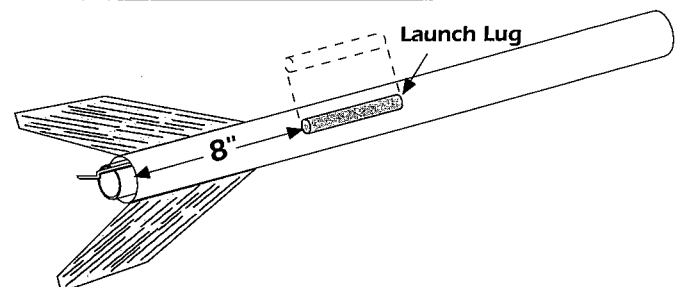

STEP 11

- A. Remove any excess plastic from inside the molded eyelet in the nose cone using a sharp hobby knife.
- B. Use two overhand knots to tie the loose end of the shock cord onto the eyelet in the nose cone.

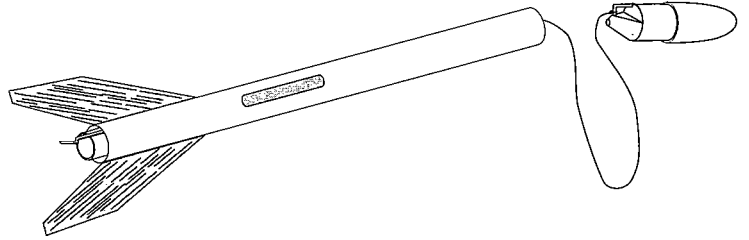

STEP 12

- A. After all the glue is completely dry, apply a coat of sanding sealer to each fin. When sealer is dry, lightly sand each fin.
- B. Repeat the sanding and sealing process until the surface of each fin is smooth.

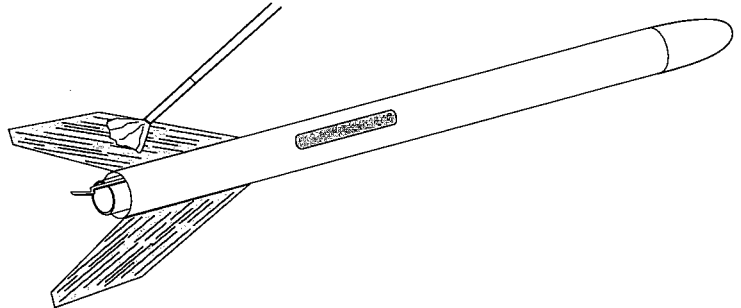

STEP 13

- A. Paint the entire rocket with gloss white spray enamel. Follow the instructions on the spray can for best results.
- B. After paint is completely dry, apply masking tape around the body tube 7 inches from the rear of the body tube. Cover the section of the body tube with paper or a plastic bag. Spray paint the entire forward section of the rocket gloss yellow. Carefully remove the masking tape after the paint is dry.

Optional Challenging Paint Scheme:

After yellow paint is dry, remove masking. Mask each one of the three fins and paint gloss yellow.

- C. When all paint is dry, apply the self-adhesive decal as shown.
NOTE: Use caution when removing the decal from the backing to prevent decal from curling over onto itself.

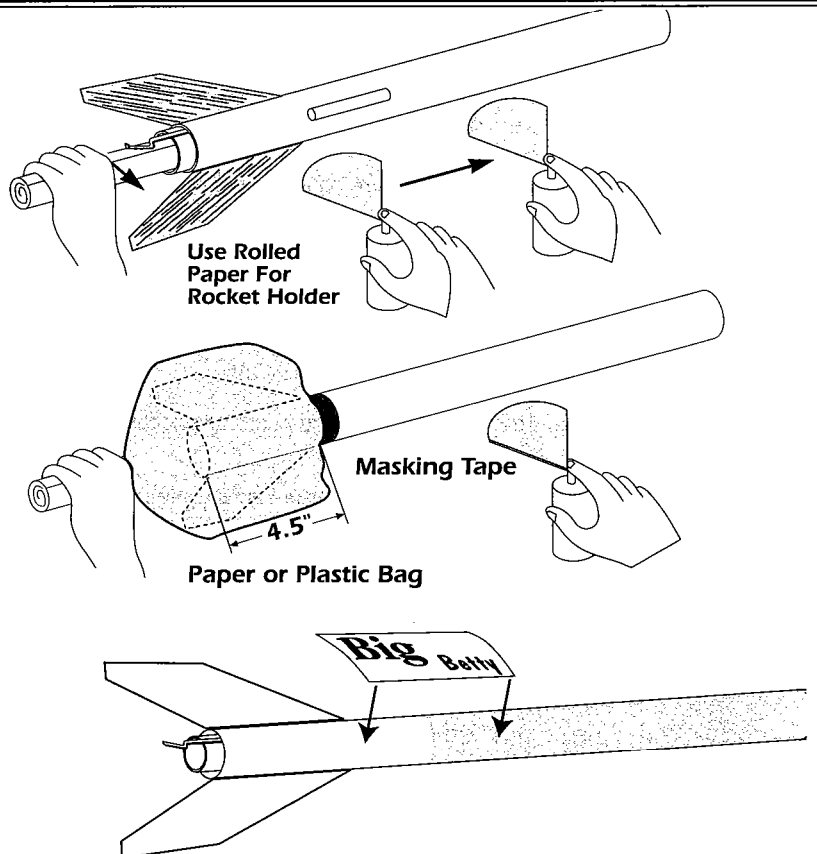

STEP 14

- A. Pass the shroud line loops of the parachute through the eyelet on the nose cone. Pass the parachute through the loop ends and pull lines tightly against the eyelet.
- B. The nose cone should fit snug but not too tight into the body tube. If the nose cone fits too tight, sand the shoulder to loosen the fit or stretch the end of the body tube slightly by inserting the pointed end of the nose cone into the body tube and gently twist it back and forth.

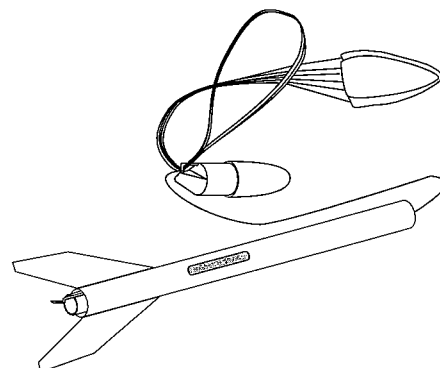

STEP 15

- A. Assemble the parachute according to the instructions printed on it.
- B. Firmly squeeze each gripper tab and parachute between your fingers.

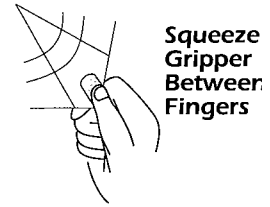
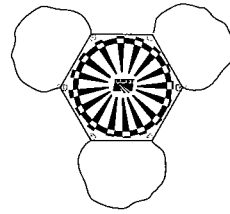

FLYING YOUR BIG BETTY™ ROCKET

WHAT ELSE YOU WILL NEED:

To successfully fly your rocket you will need the following items:

- QUEST Launch Pad (No. 7600)
- QUEST Launch Controller (No. 7500)
- QUEST Parachute Recovery Wadding (No. 7020)
- QUEST Rocket Motors, Type B6-2, B6-4, C6-3, C6-5
- Use a B6-4 Motor for your first flights.

ESTIMATED ALTITUDES

The following is a guide to assist you in determining which motor to use based on the wind conditions and size of flying field available.

MOTOR	ESTIMATED ALTITUDE
B6-4	280 FEET
C6-5	600 FEET

PREPPING YOUR ROCKET FOR FLIGHT

STEP 1

Pull the shock cord all the way out of the body tube. Crumple five sheets of recovery wadding and insert one by one into the body tube making sure that the Knot between the Kevlar and white elastic shock cord is on the nose cone side of the wadding. Wadding should fit loosely in the tube but tight enough to form a good seal against the wall of the body tube.

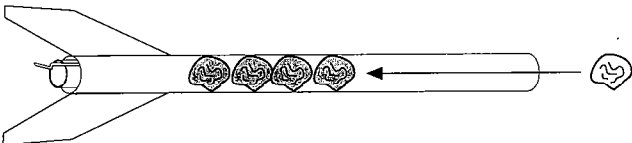

STEP 2

- A. Grab the parachute at its center and allow the rocket to hang from it. The weight of the rocket will pull the parachute into several triangular shapes.
- B. Gather the triangles together into one flat triangle.
- C. Fold the top of the parachute down over itself once.
- D. Now continue to roll the parachute over itself and roll the shroud lines around it.

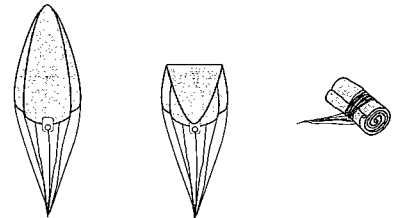

STEP 3

- A. Pack the parachute into the body tube. **THE PARACHUTE MUST SLIDE EASILY INTO THE TUBE.** If it is a tight fit, remove and re-fold the parachute.
TIP: LIGHTLY DUST YOUR PARACHUTE WITH TALCUM OR BABY POWDER TO KEEP IT FROM DEVELOPING A SET SHAPE. THIS TECHNIQUE IS ESPECIALLY EFFECTIVE IF THE WEATHER IS HOT AND HUMID OR VERY COLD.
- B. Push the shock cord into the tube and re-fit the payload Section onto the rocket. **BE CAREFUL NOT TO CATCH ANY OF THE SHOCK CORD BETWEEN THE SHOULDER OF THE PAYLOAD SECTION AND THE BODY TUBE. IF PAYLOAD SECTION FIT IS TOO LOOSE, ADD TAPE TO THE SHOULDER.**

READ AND FOLLOW THE N.A.R. SAFETY CODE DURING ALL YOUR MODEL ROCKETRY ACTIVITIES.



Manufactured by:
Quest Aerospace, Inc.
6012 East Hidden Valley Drive
Cave Creek, AZ 85331-8555